

FITTING INSTRUCTIONS

Lockout Cradle

Always work in pairs (2 skilled operatives) whenever Earth Drill unit components are being assembled or disassembled from the parent machine. Always check the weight of the attachment and ensure you have the correct equipment for handling it.



Assemble all components on firm and level ground.

Working as a pair, lift the Earth Drill into place with the port opening facing upwards. Align hood ears with the hole in the linkage block. Secure the Earth Drill with the Pin, Washer and Nylon Insert Nut, torque to 100Nm/74ft-lbs.

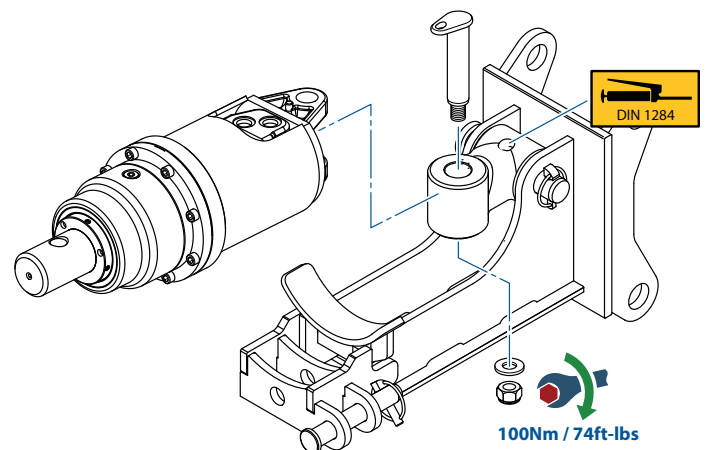
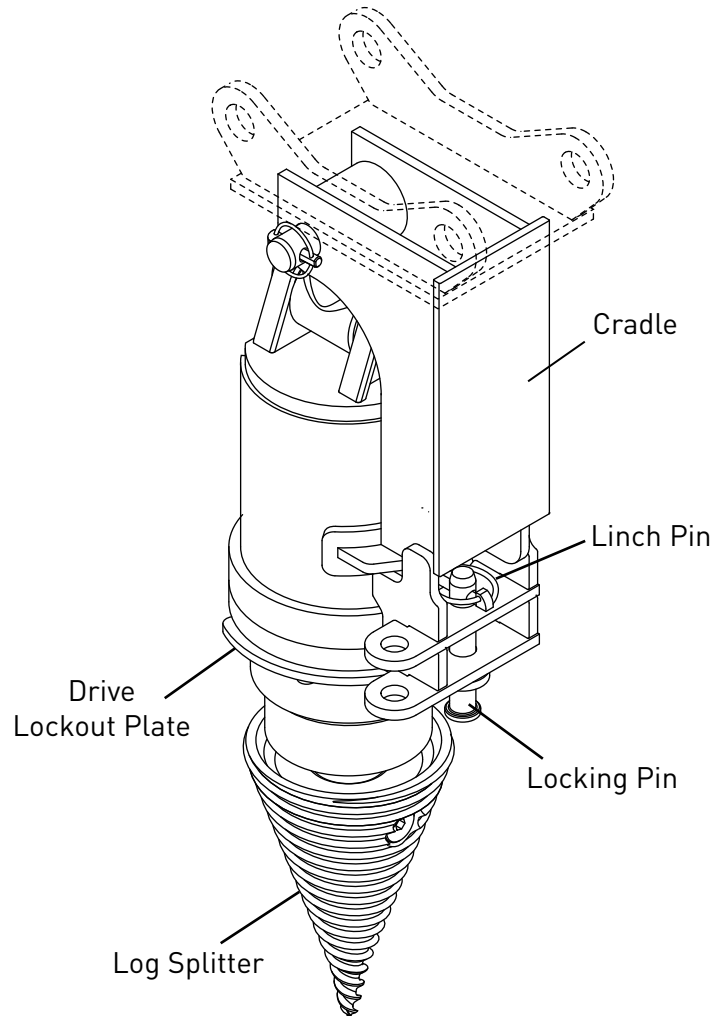
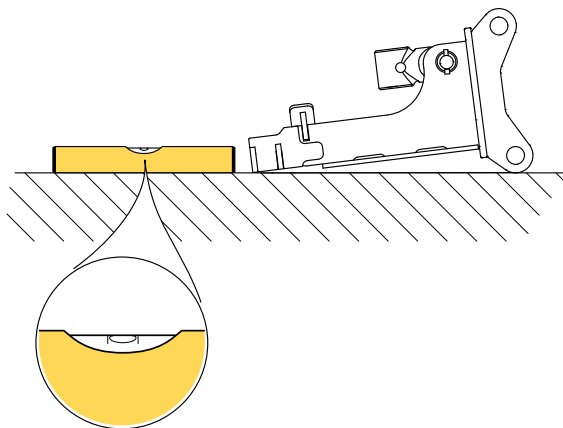

Remove six of the eight Hood fixing bolts and Washers, leaving the two uppermost in position.

Clean the 6 Hood bolts with Loctite 7063, apply Loctite 243 to bolt threads and fit Drive Lockout Plate to Earth Drill. Torque to 78Nm/58ft-lbs.

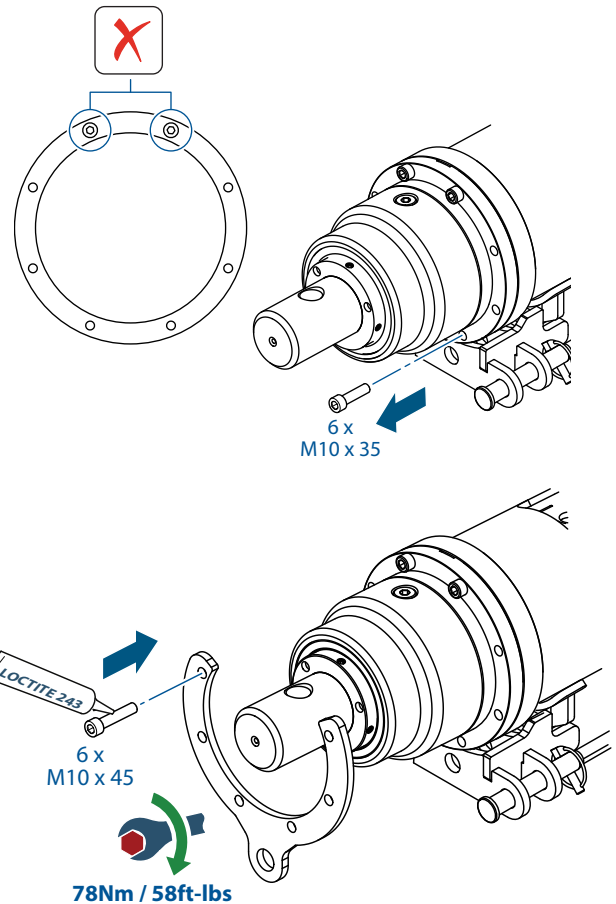

Mounting Cradle to the Parent Machine

Align the Pin holes on the Cradle and Parent Machine, push the Pins fully home and fit the Linch Pins on both sides.

Lift Drill and Cradle into a vertical position, ensure Drill is seated in the Cradle.

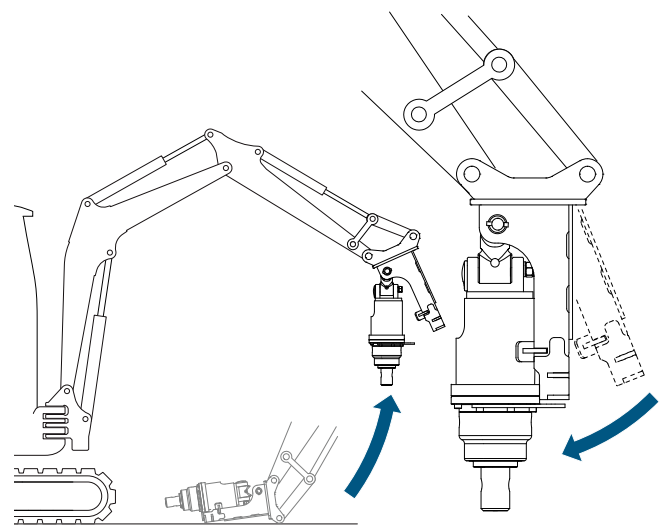
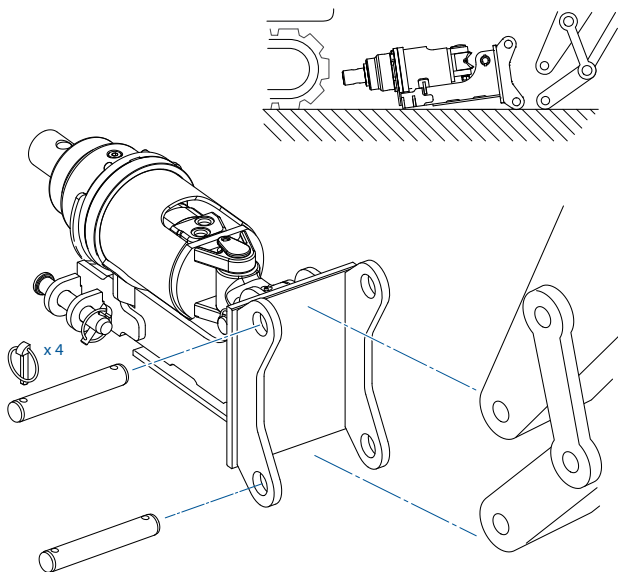

Remove Locking Pin and Linch Pin from stowage position.

Fit Locking Pin through Cradle and Drive Lockout Plate and secure with Linch Pin.

Fitting the Splitter

CHECK that the Splitter is the correct model and type to fit the Earth Drill Unit.

ENSURE that the Splitter connections are clean before fitting.

Position the Splitter in the vertical work position and support it so that it cannot fall over. Position the Earth Drill over the Splitter and align holes. Lower the Earth Drill Unit onto the Splitter and fit the Bolt. Torque to 100Nm.

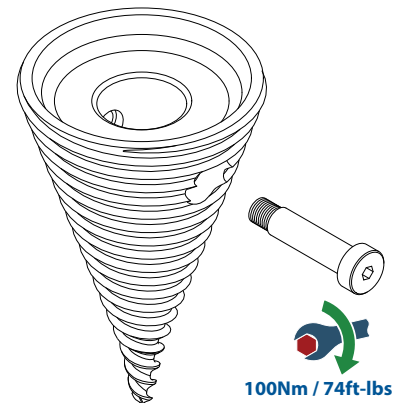
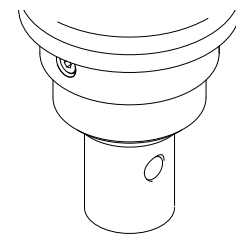
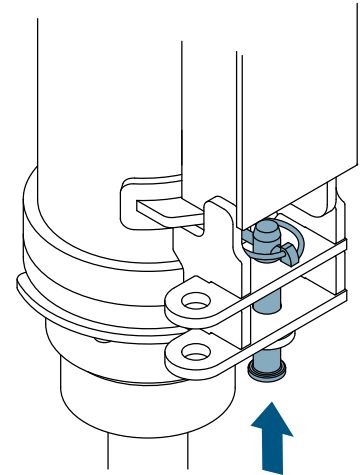
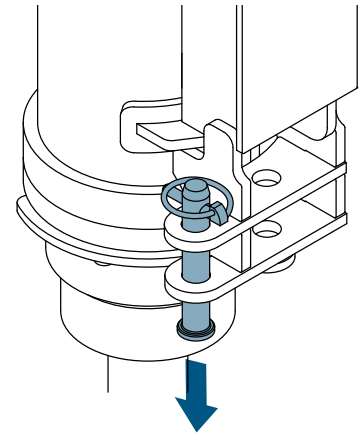

OPERATION

Engaging Splitter

Never proceed with works before completing a site risks assessment immediately before commencing work. Nominating the safe work exclusion zone radius for persons and animals as part of identifying risks and implementing controls.

Keeping the Splitter in an upright position and with a clockwise rotation, lower the Splitter so the pilot engages with the top surface of the log, drawing the tool down. Maintain a downward pressure until log splits.

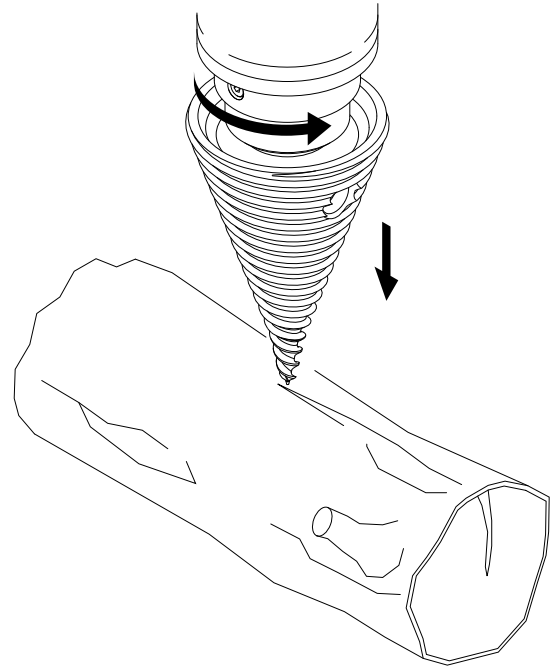

CAUTION

If downward pressure is not maintained or the log is too small, the log may begin to rotate. Should this occur, stop the Splitter, return log to safe position and apply more downward pressure before continuing.

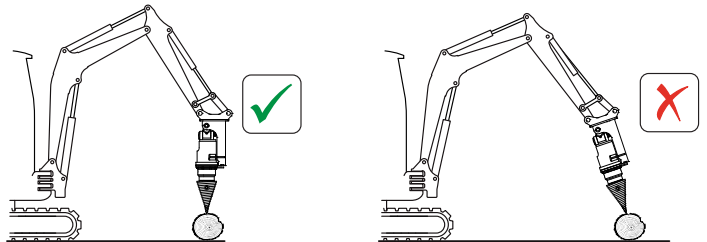

Cutting Sequence

When splitting large logs, start at one end and work along its length until log splits apart.

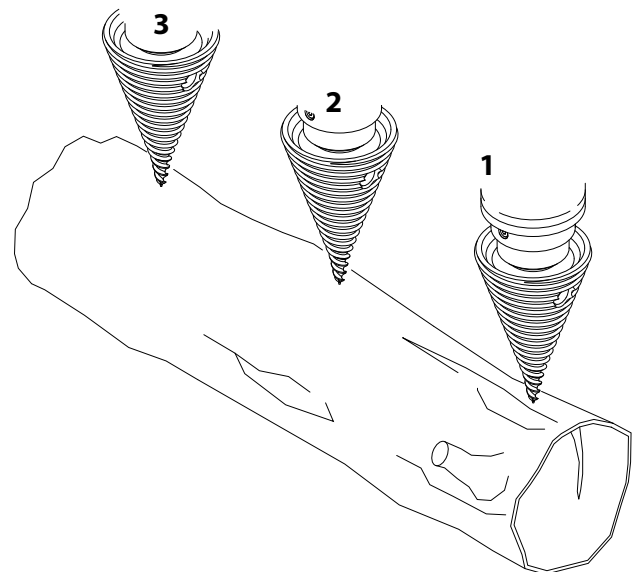

MAINTENANCE

A visual inspection of the cutting faces should be carried out before use.

WARRANTY STATEMENT

Auger Torque provide a LIFETIME parts replacement warranty on the dislodgement of the Earth Drill shaft and any failure of the Shock Lock system to prevent loss of teeth under normal operating conditions.

All Auger Torque products are warranted to be free from defects in materials or workmanship for the periods summarised below:

- Planetary Gearbox Components - 72 Months
- Hydraulic Motors - 36 Months
- All Other Parts / Products - 12 Months

The warranty periods will commence from Date of Sale by an authorised Auger Torque Dealer. Evidence of the date of sale may be required and for Planetary and Hydraulic Motor warranties to be valid the product must be registered with Auger Torque within 4 weeks of the date of sale. Extended Warranty (> 12 months) Products can be registered by returning the Registration Card or completing the form on page 8. This warranty is not transferable beyond the initial purchaser of the product.

A warranty claim should be reported to the Auger Torque Dealer who supplied the unit. The Dealer, with the technical backup of Auger Torque, will make an initial assessment.

The customer is responsible for returning the product for warranty inspection to the original supplying dealer's facility. Parts should not be delivered without the prior agreement of the dealer or Auger Torque.

During the warranty period Auger Torque, at its option, will repair or replace any parts free of charge determined as defective by Auger Torque. Such repairs will be undertaken by Auger Torque or its nominated representative at an Auger Torque facility or a location deemed suitable by Auger Torque. Auger Torque are not liable for any associated costs relating to a warranty failure.

Parts repaired or replaced by Auger Torque are then covered by this warranty for the remainder of the original warranty as if such parts were original parts.

Products or parts which, as determined by Auger Torques examination, show wear from normal use, have been improperly operated, damaged by accident or negligence, altered or modified are not considered defective and are not covered by this warranty.

This warranty is void if any attempt is made to make field repairs unless these have been pre-approved in writing by Auger Torque.

This warranty is void if the products are not serviced in-line with the instructions in the Operators Manual. Particular care should be taken to perform regular oil changes in gearboxes.

This warranty is exclusive and in-lieu of any other expressed warranties. There are no warranties of merchantability or fitness for a particular purpose. Auger Torque shall not be liable for any consequential, incidental or punitive damages, losses or expenses, including those resulting from or caused by any defects.

As you would expect from Auger Torque, with our extensive experience and product reliability we'll always go the extra mile to keep you working.



YOUR DEALER IS

Auger Torque Europe Ltd

Hazleton
Cheltenham
GL54 4DX
England

Tel: +44(0)1451 861652

Fax: +44(0)1451 861660

Email: sales@augertorque.com

Auger Torque Australia Pty Ltd

122 Boundary Rd
Rocklea
Queensland 4106
Australia

Tel: +61(0)7 3274 2077

Fax: +61(0)7 3274 5077

Email: sales@augertorque.com.au

Auger Torque USA LLC

2640 Jason Industrial Parkway
Winston, GA 30187
USA

Tel: (+1) 844 287 6300

Fax: (+1) 770 947 9916

Email: sales@augertorqueusa.com

www.augertorque.com



Products and specifications subject to change without prior notice.

Some products may not be available in your country or region.

AUGER TORQUE, SHOCK LOCK™, NDS™ and the AUGER TORQUE LOGO are trademarks of Auger Torque Europe Ltd © 2020 Auger Torque Europe Ltd. All Rights Reserved.