



Auger Torque T150 Hedge Trimmer for Excavator and Skidsteer

The **Auger Torque Hedge Trimmer** is the perfect addition for excavators (1.5 – 8T) and skidsteer loaders, and offers a variety of motor sizes to suit your application. Attaching to an excavator provides extra-long cutting reach, gaining access to those taller trees and deeper hedges. The newly designed skidsteer mounting frame allows you to quickly switch the Hedge Trimmer between left and right sides of the skidsteer. The Hedge Trimmer is also ideal for cutting long grass and brush.

Attaching the optional tooth extension bar provides a full 2.5m cutting length. This is sure to make trimming more precise, efficient and will provide yet another way to expand the versatility of existing machines.

A neat and accurate cut, every time.



optional 1m extension

Features

- ▶ 1.5m cutting length
- ▶ Optional 1m cutting extension bar
- ▶ Cuts up to 40mm diameter
- ▶ Replace individual cutting teeth as required
- ▶ Hoses included
- ▶ Delivered ready to use

Visit the Auger Torque website to watch a demo

Specifications

T150 HEDGE TRIMMER

50cc Motor Variant

Suited to: Excavators 1.5-2.5 T
Skidsteer Loaders

Oil Pressure Range: 150-220 Bar (2176-3191 psi)
Oil Flow Range: 30-48 lpm (7.9-12.7 gpm)
Max. Cutting Diameter: 25 mm (0.98")

80cc Motor Variant

Suited to: Excavators 2.5-4.5 T
Skidsteer Loaders

Oil Pressure Range: 150-220 Bar (2176-3191 psi)
Oil Flow Range: 40-68 lpm (10.6-18.0 gpm)
Max. Cutting Diameter: 40 mm (1.58")

100cc Motor Variant

Suited to: Excavators 4.5-8 T
Skidsteer Loaders

Oil Pressure Range: 150-220 Bar (2176-3191 psi)
Oil Flow Range: 50-71 lpm (13.2-18.8 gpm)
Max. Cutting Diameter: 40 mm (1.58")

Max. Back Pressure: 20 Bar (290 psi)
Hose Port Diameter: 1/2" BSP
Cutting Length: 1500 mm (59")

Dimensions (h x w x l):
203 mm x 270 mm x 1537 mm
(7.99" x 10.61" x 60.5")

Weight: 69 kg (152 lb)

EXTENSION

Cutting Length: 1 m (40")
Combined Cutting Length: 2.5 m (100")
Max. Cutting Diameter: 40 mm (1.58")
(dependent on motor variant)

Dimensions

118 mm x 1192 mm x 225 mm (h x w x d)
(4.65in x 46.93in x 8.86in) (h x w x d)

Weight

69 kg (57.3 lbs)

OFFSET MOUNT

Max. Offset Distance: 1.3 m (51")
Cutting Angle: Horizontal thru Vertical
Operating Voltage: 12V
Dimensions (h x w x d):
420 mm x 245 mm x 1510 mm
(16.46" x 9.69" x 59.33")

Weight: 56 kg (124 lbs)

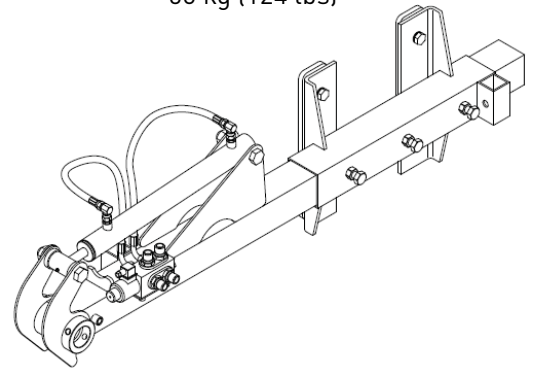

Part of the Auger Torque landscaping range

STUMP PLANERS | LOG SPLITTERS | MULCHERS | HEDGE TRIMMERS | SWEEPER BROOMS